

I N S T R U C T I O N S

MODEL 430A

MICROWAVE POWER METER

SPECIFICATIONS

Power Range--

Milliwatts	Decibels Above or Below 1 mw.
.1	-10
.3	-5
1	0
3	+5
10	+10

Accuracy--

+5% of full scale.

Required External Equipment--

Bolometer and mount. 200 ohms, at 8.40 to 8.90 Ma, at 25°C.

Power Supply Rating--

Voltage-- 105 - 125 volts

Frequency-- 50/60 cycles.

Wattage-- 60 watts

Overall Dimensions--

12 $\frac{1}{2}$ " long x 10-3/8" wide x 9 $\frac{1}{2}$ " high.

Weight--

17 lbs.

Cables--

	<u>Type of Cable</u>	<u>Length</u>	<u>Terminations</u>
Input Cable	RG-58/U	3 ft.	UG-88/U Plug on one end, no termination other end.

430A
11-14-49
SERIAL 7670

OPERATING INSTRUCTIONS:

Inspection

This instrument has been thoroughly tested and inspected before being shipped.

After the instrument is unpacked it should be carefully inspected for any damage received in transit. If any shipping damage is found, follow the procedure outlined in the "Claim For Damage In Shipment" page at the back of this instruction book.

Controls and Terminals

"ON" This toggle switch controls power supplied to the instrument from the power line.

"FUSE" The fuseholder, located on the control panel, contains a two ampere cartridge fuse, which may be replaced by unscrewing the fuseholder cap and inserting a new fuse.

"COARSE ZERO" This variable resistor provides a coarse adjustment of the meter zero indication.

"FINE ZERO" This variable resistor provides a fine adjustment of the meter zero indication.

"DBM-MW" This range switch is used to select the desired power measurement range of the instrument.

Input Jack This UG-185/U jack will fit any one of the BNC series of connectors.

"CAL" The binding post marked "CAL" is located on the chassis and is connected to the input of the amplifier. It is used to connect the external calibration voltage to the amplifier.

Operation

Before this instrument can be operated a bolometer and bolometer mount of the correct characteristics must be selected.

The Model 430A is designed to operate with a bolometer which has a positive temperature coefficient, such as a Sperry Gyroscope Company Type 821 barretter or a one-hundredth ampere instrument fuse.

Any bolometer is satisfactory provided the instrument can be zeroed. On the 10 mw. range the instrument can be zeroed at any temperature from 10°C to 50°C, with any bolometer whose resistance is 200 ohms within the range from 8.40 ma to 8.90 ma,

430A 11-14-49 SERIAL 7676

at 25°C. On lower ranges a wider variation in bolometer is permissible, so that, although a bolometer may not be useable on the top range, it may still be perfectly satisfactory at lower ranges.

Because of the wide variation in characteristics of instrument fuses, not all fuses will be useable in the Model 430A. Those giving a minimum reading above zero cannot be used, as they require less power to make 200 ohms than can be reached by the Model 430A. Those giving a maximum reading below zero, however, can be changed in characteristics and made useable by the following procedure.

Connect the fuse across a signal generator and apply approximately fifty milliwatts of power to the fuse momentarily. Then test the fuse in the Model 430A to see if its characteristics have changed enough to produce a zero meter indication. If the fuse needs more correction, apply a little more power from the signal generator and then test in the Model 430A. Repeat the above procedure until the fuse is correct.

Step by Step Operating Procedure

1. Connect the bolometer and mount to the input cable supplied with the Model 430A. Do not apply radio frequency power to the bolometer.
2. Turn on the instrument and allow five minutes for it to heat-up to operating temperature.
3. Set the range switch to the desired range, and with no radio frequency applied to the bolometer, set the "COARSE ZERO" and "FINE ZERO" controls until the meter indicates zero.
4. Apply radio frequency power from the equipment to be measured. Then adjust the tuning device in the bolometer mount for maximum meter indication. The resultant meter indication shows the power output of equipment under test in milliwatts and decibels about one milliwatt.
5. Always adjust for zero meter indication (no RF power input during adjustment) after changing from one range to another. The "COARSE ZERO" control should be turned slowly when adjusting the lower ranges, otherwise the meter needle will go off-scale violently. The meter may drift slightly on the lower ranges, so for greatest accuracy, the instrument should be zeroed just before making a measurement.

GENERAL INFORMATION

The Model 430A Microwave Power Meter consists of a self-balancing bridge, an amplifier, a metering circuit, and a regulated power supply.

The self-balancing bridge includes the circuits associated with V1 and V3. The bridge operates in the input circuit of V1,

430A
11-14-49
SERIAL 7670

while the output of V3 is coupled to the input of V1 through the bridge. The circuits are arranged so that the output of V3 is in phase with the input of V1; thus, there being sufficient gain, the system oscillates. The frequency of oscillation is controlled by the bridge values which are such as to permit the system to oscillate at a frequency of approximately 10 kcs.

One arm of the bridge is the bolometer, a non-linear resistor. This non-linear element limits the level of oscillation to the point where the sum of the audio, dc, and rf power causes the bolometer to have a resistance value necessary for stable operation of the oscillator.

The crystal diode CRL is provided in a protective circuit for the bolometer in order to limit the surge voltage at the input jack if the bolometer is connected after the instrument is turned on.

It should be noted that power applied to the bolometer from an outside source tends to cause the resistance of the bolometer to increase because of its positive temperature coefficient. This action results in a lowered signal applied to the grid of V1 so that, in turn, less power is applied to the bolometer from the output of V3. Therefore, the level of oscillation decreases, the change in level being automatically the proper amount to insure that the resistance of the bolometer remains unchanged.

The output of V3 is applied to the amplifier V4 and V5 through a resistive meter multiplier circuit. The output of the amplifier is then applied to the full-wave rectifier and metering circuit associated with M1.

Because of the fact that the application of external power to the bolometer causes the level of oscillation of the oscillator to decrease a conventional metering circuit would indicate the application of external power as a decreased meter reading. In order to avoid this effect, the meter circuit has been designed to operate with a dc current through it of such amplitude as would cause a reading somewhat higher than full-scale. The output of the amplifier is then connected to the meter circuit in such a way that the rectified output of the amplifier flows through the meter in a reverse or negative direction and therefore bucks the dc biasing current. As a result, when the amplitude of oscillation of the oscillator is greatest (no RF power applied to the bolometer), the meter reading is zero. The decrease in level of oscillation caused by external power being delivered to the bolometer results in less rectified signal current flowing through the meter so that the meter reading increases. The meter is calibrated directly in milliwatts and dbm.

The power supply for the instrument includes a full-wave rectifier circuit and a degenerative type voltage regulator circuit for maintaining a constant plate supply voltage for the remainder of the circuit.

11-14-49 SERIAL 76 to

430A

SERVICE NOTES:

Cover and Bottom Plate Removal

The cover of the instrument is removed by unscrewing the four screws at the back of the instrument and sliding the top of the cover away from the panel.

The bottom plate comes off when the four screws in the plate are removed.

Tube Replacement

When replacing tubes in the Model 430A any tube of average type characteristics can be used. However when V₄, V₅, or V₉ are replaced it is usually necessary to adjust their associated circuits. The adjustments are performed as follows:

Replacement of V₄ or V₅

When replacing tube V₄ or V₅, it is desirable to check the gain of the amplifier because variations in the gain of these tubes will affect the accuracy of the instrument. The gain adjustment procedure is as follows:

1. Remove tube V₃ from its socket and apply .472 volts at 10 KC between the "CAL" binding post and the chassis.
2. If the meter does not indicate zero, adjust "R31" so that it indicates zero.
3. Change the applied voltage to .193 volts at 10 KC and adjust "R39" for full scale meter indication.
4. Steps 1, 2, and 3 should be repeated because of slight interlocking between the R31 and R39 adjustments.

Replacement of V₉

The voltage across V₉ determines the value of bucking current for the meter. A new tube may change the bucking current and the accuracy of the instrument. The instrument should be readjusted by following the procedure used when V₄ or V₅ are replaced.

Voltage Regulator Adjustment

Adjust R51 (which is located on the resistor board beneath V7-6Y6 tube) so that the voltage between pin #8 of V7 and the chassis is 240 volts.

Crystal Rectifier Selection

Crystal CR 1, 2, 3, 4, & 5 should be selected to have a back resistance of not less than 50,000 ohms measured at 65°C, on an ohmmeter with an internal battery of 3 volts and series resistance of 100,000 ohms. Inasmuch as resistance in the reverse direction is almost proportional to voltage at low voltages, any ordinary ohmmeter can be used if the resistance reading obtained is used to calculate the back current. In this case, the back current should not exceed .02 Ma. If ordinary unselected crystals are installed, they may result in error in the readings because of a large decrease in back resistance at high temperatures.

430A 11-14-49 SERIAL 7670

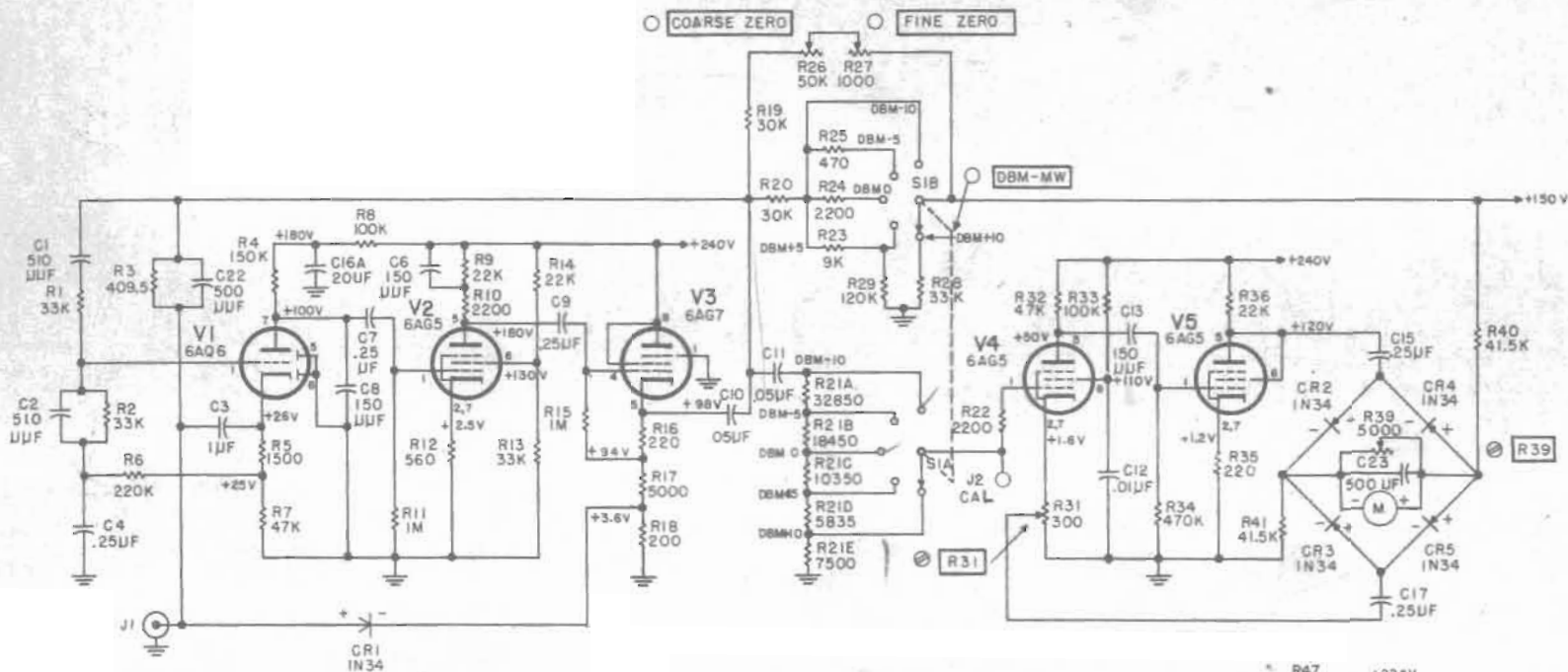

CONDITIONS OF DC VOLTAGE MEASUREMENT

1. 115V, 60 \sim POWER SUPPLY
2. MEASURED BETWEEN THE INDICATED POINTS AND CHASSIS WITH A VOLTMETER OF 100 MEGOHMS INPUT RESISTANCE
3. INPUT OPEN, RANGE SWITCH IN ANY POSITION

* FACTORY ADJUSTMENT

○ PANEL CONTROL

⊕ SCREWDRIVER ADJ.

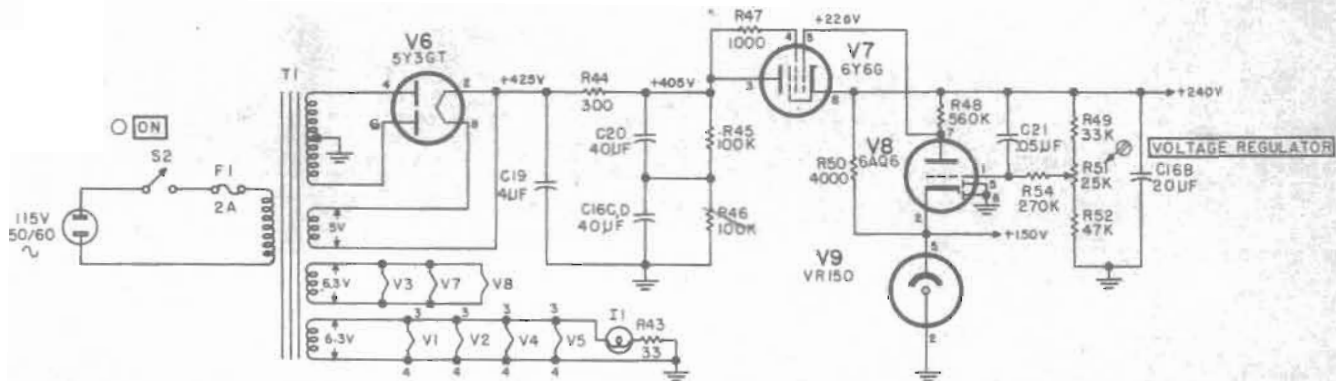

SCHEMATIC DIAGRAM OF *hp*-MODEL 430A MICROWAVE POWER METER SERIAL 76 TO

**PROPERTY OF
TEST ENGINEERING
DEPT. 21**

TABLE OF REPLACEABLE PARTS

Circuit Ref.	Description	-hp- Stock No.	Mfr. & Mfrs. Designation
C1	Capacitor: fixed; mica; 510 mmf; $\pm 1\%$; 500 vdcw	15-27	Sangamo: Type J.
C2	Capacitor: fixed; mica; 510 mmf; $\pm 1\%$; 500 vdcw	15-27	Sangamo: Type J.
C3	Capacitor: fixed; paper; 1 mf; $\pm 10\%$; 600 vdcw	17-12	General Electric: 23F467 G103
C4	Capacitor: fixed; paper; .25 mf; 200 vdcw	16-36	Sprague: 68P
C5	This Circuit Reference not assigned.		
C6	Capacitor: fixed; mica; 150 mmf; $\pm 10\%$; 500 vdcw	14-150	Mic amold: OXM
C7	Capacitor: fixed; paper; .25 mf; 600 vdcw	16-42	Sprague: 68P37
C8	Capacitor: Same as C6		
C9	Capacitor: Same as C7		
C10	Capacitor: fixed; paper; .05 mf; 600 vdcw	16-15	Aerovox: Type 684
C11	Capacitor: Same as C10		
C12	Capacitor: fixed; dielectric; .01 mf; 600 vdcw; $\pm 20\%$	16-41	Solar Mfg. Corp. ST-6-01
C13	Capacitor: fixed; mica; 150 mmf; $\pm 10\%$; 500 vdcw	14-150	Micamold: OXM
C14	This Circuit Reference not assigned.		
C15	Capacitor: fixed; paper; .25 mf; 600 vdcw	16-42	Sprague: 68P37
C16a, b, c, d.	Capacitor: fixed; electrolytic; 4 sections each 20 mf; 450 vdcw	18-42	Mallory: FPQ-444
C17	Capacitor: fixed; paper; .25 mf; 600 vdcw	16-42	Sprague: 68P37
C18	This Circuit Reference not assigned.		

430A 1-14-49 SERIAL 7676

TABLE OF REPLACEABLE PARTS

Circuit Ref.	Description	-hp- Stock No.	Mfr. & Mfrs. Designation
C19	Capacitor: fixed; paper; 4 mf; 600 vdcw	17-10	Cornell-Dubilier: TLA-6040
C20	Capacitor: fixed; electrolytic; 40 mf; 450 vdcw	18-40	Mallory: Type FPS-146
C21	Capacitor: fixed; paper; .05 mf; 600 vdcw	16-15	Aerovox: Type 684
C22	Capacitor: fixed; mica; 500 mmf; <u>±10%</u> ;	14-500	Micamold: Type OXM
C23	Capacitor: fixed; electrolytic; 500 mmf; 15 vdcw	18-5	Mallory: Type TC-1505
CR 1,2 3,4,5.	CRYSTAL RECTIFIER: type IN34 selected. See Service Notes section.	212-34	Sylvania Electric, Electronic Divn.
F1	Fuse: 2 amp; type V3AG	211-2	Littelfuse:
I1	Lamp: 6-8v; 0.15 amp; min bay base	211-47	General Elec- tric. 47
J1	Receptacle: UG-185/U	38-99	Industrial Products: 4500
J2	Binding Post	312-3	Hewlett- Packard
M1	Meter	43A-81	Hewlett- Packard
R1, R2	Resistor: precision compo- sition type; 33,000 ohms; <u>±1%</u> .	31-33K	Wilkor: CP-1
R3	Resistor: precision wirewound; 409.5 ohms; <u>±1%</u> ; $\frac{1}{2}$ watt	26-19	Shalleross: Type 140L
R4	Resistor: composition; 150,000 ohms; <u>±10%</u> ; 1 watt	24-150K	Allen-Bradley GB-1541
R5	Resistor: composition; 1500 ohms; <u>±10%</u> ; 1 watt	24-1500	Allen-Bradley GB-1521
R6	Resistor: composition; 220,000 ohms; <u>±10%</u> ; 1 watt	24-220K	Allen-Bradley GB-2241

430A 11-14-49 SERIAL 76 To

TABLE OF REPLACEABLE PARTS

Circuit Ref.	Description	-hp- Stock No.	Mfr. & Mfrs. Designation
R7	Resistor: composition; 47,000 ohms; $\pm 10\%$; 1 watt	24-47K	Allen-Bradley: GB-4731
R8	Resistor: composition; 100,000 ohms; $\pm 10\%$; 1 watt	24-100K	Allen-Bradley: GB-1051
R9	Resistor: composition; 22,000 ohms; $\pm 10\%$; 1 watt	24-22K	Allen-Bradley: GB-2231
R10	Resistor: composition; 2200 ohms; $\pm 10\%$; 1 watt	24-2200	Allen-Bradley: GB-2221
R11	Resistor: composition; 1 megohm; $\pm 10\%$; 1 watt	24-1M	Allen-Bradley: GB-1061
R12	Resistor: composition; 560 ohms; $\pm 10\%$; 1 watt	24-560	Allen-Bradley: GB-5611
R13	Resistor: composition; 33,000 ohms; $\pm 10\%$; 1 watt	24-33K	Allen-Bradley: GB-3331
R14	Resistor: composition; 22,000 ohms; $\pm 10\%$; 1 watt	24-22K	Allen-Bradley: GB-2231
R15	Resistor: composition; 1 megohm; $\pm 10\%$; 1 watt	24-1M	Allen-Bradley: GB-1061
R16	Resistor: composition; 220 ohms; $\pm 10\%$; 1 watt	24-220	Allen-Bradley: GB-2211
R17	Resistor: composition; 5,000 ohms; $\pm 10\%$; 20 watts	27-3	Lectrohm Inc. Type 2R
R18	Resistor: composition; 200 ohms; $\pm 5\%$; 1 watt	24-81	Allen-Bradley: GB-2015
R19	Resistor: fixed wirewound; 30,000 ohms; $\pm 1\%$; 1 watt	26-11	Lectrohm: 1-3/4E
R20	Resistor: fixed; wirewound; 30,000 ohms; $\pm 1\%$; 1 watt	26-11	Lectrohm: 1-3/4E
R21A to R21E	(See- S-1) Part of Range Switch Assembly		
R22	Resistor: composition; 2,200 ohms; $\pm 10\%$; 1 watt	24-2200	Allen-Bradley: GB-2221

11-14-49 SERVIC 76 T6

430A

TABLE OF REPLACEABLE PARTS

Circuit Ref.	Description	-hp- Stock No.	Mfr. & Mfrs. Designation
R23	Resistor: precision composition; 9000 ohms; 1 watt	31-9K	Wilkor: CP-1
R24	Resistor: composition; 2200 ohms; $\pm 10\%$; 1 watt	24-2200	Allen-Bradley: GB-2221
R25	Resistor: composition; 470 ohms; $\pm 10\%$; 1 watt	24-470	Allen-Bradley: GB-4711
R26	Potentiometer: composition; 50,000 ohms	310-61	
R27	Potentiometer: wirewound; 1000 ohms	210-5	Centralab: 21-010-355
R28	Resistor: composition; 33000 ohms; $\pm 10\%$; 2 watts	25-33K	Allen-Bradley: HB-3331
R29	Resistor: composition; 120,000 ohms; $\pm 10\%$; 1 watt	24-120K	Allen-Bradley: GB-1241
R30	This Circuit Reference Not Assigned.		
R31	Potentiometer: composition; 300 ohms	210-25	Centralab: BA-33-010-1466
R32	Resistor: composition; 47,000 ohms; $\pm 10\%$; 1 watt	24-47K	Allen-Bradley: GB-4701
R33	Resistor: composition; 100,000 ohms; $\pm 10\%$	24-100K	Allen-Bradley: GB-1041
R34	Resistor: composition; 470,000 ohms; $\pm 10\%$; 1 watt	24-470K	Allen-Bradley: GB-4741
R35	Resistor: composition; 220 ohms; $\pm 10\%$; 1 watt	24-220	Allen-Bradley: GB-2211
R36	Resistor: composition; 22,000 ohms; $\pm 10\%$; 2 watts	25-22K	Allen-Bradley: GB-2231
R37	This Circuit Reference Not Assigned.		
R38	" " " " "		
R39	Potentiometer: wirewound; 5000 ohms.	210-7	Centralab: 21-010-357
R40	Resistor: precision composition type; 41,500 ohms; $\pm 1\%$; 1 watt	31-41.5K	Wilkor: CP-1

430A 11-44-49 SERIAL 7676

TABLE OF REPLACEABLE PARTS

Circuit Ref.	Description	-hp- Stock No.	Mfr. & Mfrs. Designation
R41	Resistor: precision composition; 41,500 ohms; $\pm 1\%$; 1 watt	31-41.5K	Wilkor: CP-1
R42	This Circuit Reference not assigned.		
R43	Resistor: composition; 33 ohms; $\pm 10\%$; 1 watt	24-33	Allen-Bradley: GB-3301
R44	Resistor: wirewound; 300 ohms; $\pm 10\%$; 1 watt	28-3	Lectrohm: 1-3/4EV
R45	Resistor: composition; 100,000 ohms; $\pm 10\%$; 1 watt	24-100K	Allen-Bradley: GB-1041
R46	Resistor: composition; 100,000 ohms; $\pm 10\%$; 1 watt	24-100K	Allen-Bradley: GB-1041
R47	Resistor: composition; 1000 ohms; $\pm 10\%$; 1/2 watt	23-1000	Allen-Bradley: GB-1031
R48	Resistor: composition; 560,000 ohms; $\pm 10\%$; 1 watt	24-560K	Allen-Bradley: GB-5641
R49	Resistor: composition; 33,000 ohms; $\pm 10\%$; 1 watt	24-33K	Allen-Bradley: GB-3331
R50	Resistor: wirewound; 400 ohms; $\pm 10\%$; 10 watts	27-7	Lectrohm: Type 2R
R51	Potentiometer; composition; 25,000 ohms.	210-11	Centralab: 1-010-1990
R52	Resistor: composition; 47,000 ohms; $\pm 10\%$; 1 watt	24-47K	Allen-Bradley: GB-4731
R53	This Circuit Reference not assigned.		
R54	Resistor: composition; 270,000 ohms; $\pm 10\%$; 1 watt	24-270K	Allen-Bradley: GB-2741
S1	Range Switch Assembly: includes S1A, S1B, and Resistors R21A to R21E.	43A-19W	Hewlett-Packard
S2	Switch: toggle: SPST	310-1	Arrow H & H.
T1	Power Transformer:	910-8	Hewlett-Packard

430A 11-14-49 SERIAL 7676

TABLE OF REPLACEABLE PARTS

Circuit Ref.	Description	-hp- Stock No.	Mfr. & Mfrs. Designation
V1	Tube: RMA type 6AQ6	212-6AQ6	
V2	Tube: RMA type 6AG5	212-6AG5	
V3	Tube: RMA type 6AG7	212-6AG7	
V4	Tube: RMA type 6AG5	212-6AG5	
V5	Tube: RMA type 6AG5	212-6AG5	
V6	Tube: RMA type 5Y3GT	212-5Y3GT	
V7	Tube: RMA type 6Y6G	212-6Y6G	
V8	Tube: RMA type 6AQ6	212-6AQ6	
V9	Tube: RMA type VR150	212-VR150	
	Knob: 1½" diam.	37-11	Kurz-Kasch: S-380-64-DD- L-522
	Knob: 2-1/16" diam.	37-13	Kurz-Kasch: S-311-64-DD- 522
	Min Tube Shield: 1-3/4" h.	38-28	Cinch: 8661
	Min Tube Shield: 2" h	38-68	Eby: 8694
	Fuseholder	312-8	Littelfuse: 342001

CLAIM FOR DAMAGE IN SHIPMENT

The instrument should be tested as soon as it is received. If it fails to operate properly, or is damaged in any way, a claim should be filed with the carrier. A full report of the damage should be obtained by the claim agent, and this report should be forwarded to us. We will then advise you of the disposition to be made of the equipment and arrange for repair or replacement. Include model number, type number and serial number when referring to this instrument for any reason.

WARRANTY

Hewlett-Packard Company warrants each instrument manufactured by them to be free from defects in material and workmanship. Our liability under this warranty is limited to servicing or adjusting any instrument returned to the factory for that purpose and to replace any defective parts thereof (except tubes, fuses and batteries). This warranty is effective for one year after delivery to the original purchaser when the instrument is returned, transportation charges prepaid by the original purchaser, and which upon our examination is disclosed to our satisfaction to be defective. If the fault has been caused by misuse or abnormal conditions of operation, repairs will be billed at cost. In this case, an estimate will be submitted before the work is started.

If any fault develops, the following steps should be taken:

1. Notify us, giving full details of the difficulty, and include the model number, type number and serial number. On receipt of this information, we will give you service instructions or shipping data.

2. On receipt of shipping instructions, forward the instrument prepaid, and repairs will be made at the factory. If requested, an estimate of the charges will be made before the work begins provided the instrument is not covered by the warranty.

SHIPPING

All shipments of Hewlett-Packard instruments should be made via Railway Express. The instruments should be packed in a wooden box and surrounded by two to three inches of excelsior or similar shock-absorbing material.

DO NOT HESITATE TO CALL ON US

HEWLETT-PACKARD COMPANY

Laboratory Instruments for Speed and Accuracy

395 PAGE MILL ROAD

PALO ALTO, CALIF.





LABORATORY INSTRUMENTS OF SPEED AND ACCURACY

Standard -hp- instruments shown here are adaptable for making nearly every electronic measurement in the electronic field. Following is a brief description of a few of these instruments. Complete technical information will be sent—without obligation—on request. In addition, -hp- engineers are at your service to help solve special problems.



WIDE-BAND VOLTMETER

-hp- Model 400C Vacuum Tube Voltmeter features both a wide voltage and wide frequency range, with a high input impedance of 10 megohms. The instrument measures from 1 millivolt to 300 v full scale in 12 ranges. Accuracy is within 3% 20 cps to 100 kc; 5%, 20 cps to 2 mc. Instrument includes decibel scale (0 db = 1 mw, 600 ohms), making available continuous readings, -72 to +52 dbm. (-hp- also makes low frequency and battery operated voltmeters.)



H-F VACUUM TUBE VOLTMETER

-hp- 410A High Frequency Vacuum Tube Voltmeter combines in one instrument an ac voltmeter covering frequencies from 20 cps to 700 mc, a dc voltmeter with 100 megohms input impedance, and an ohmmeter capable of measuring resistances from .2 ohms to 500 megohms. The special probe places a capacity of 1.3 uufd across the circuit under test. Input resistance for ac measurements is 6 megohms. Six voltage ranges provide full-scale sensitivities from 1 to 300 volts.



WIDE-BAND AMPLIFIER

-hp- 450A Amplifier is a new, versatile, wide-band amplifier designed for general laboratory or production use. It provides exceptional stability at 40 or 20 db gain, and gives new freedom from spurious responses. Low phase shift is assured by a straight-forward, resistance-coupled amplifier design, together with inverse feed back. Frequency response is flat within 1/2 db between 10 and 1,000,000 cps. Varying tube voltages or aging tubes have no appreciable effect on the gain or other characteristics. When used in conjunction with -hp- 400A Vacuum Tube Voltmeter, it increases voltmeter sensitivity 100 times.

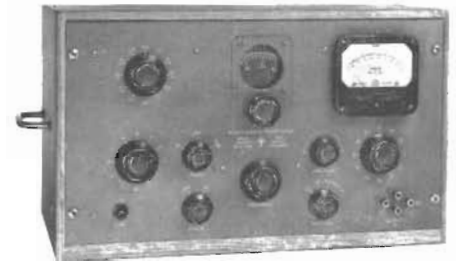

AUDIO SIGNAL GENERATORS

-hp- Model 206A Audio Signal Generator is specially designed for am and fm broadcast measurements. Frequency range is 20 cps to 20 kc. Distortion is less than 0.1%, 50 cps to 20 kc; and 0.25% down to 20 cps. Attenuators are adjustable from 0 to 111 db of attenuation in 0.1 db steps. Maximum output is +15 dbm. Balanced center-tapped output system matches 600, 150 or 50 ohm systems. Other -hp- audio signal generators provide up to 5 watts power between 20 cps to 100 kc.



RESISTANCE-TUNED AUDIO OSCILLATORS

-hp- Resistance-Tuned Oscillators are suitable for almost every type of work. Their low distortion makes them particularly valuable in making distortion measurements on audio amplifiers, broadcast transmitters and other equipment. They provide an excellent source of voltage for accurate bridge measurements. The output is sufficient to drive signal generators and other equipment requiring considerable power. Their wide frequency range also makes them suitable for work in the supersonic region.

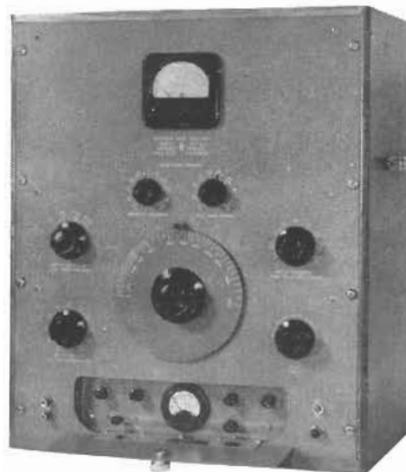

HARMONIC WAVE ANALYZER

-hp- Model 300A Harmonic Wave Analyzer is an excellent instrument for both laboratory and production work where accurate and rapid measurement of individual components of a complex wave is required. The maximum selectivity is sufficient for measurement of harmonics of frequencies as low as 30 cycles and it can be varied over a wide range. With this variable selectivity feature, measurements at higher frequencies can be made more rapidly, yet with no sacrifice in accuracy.

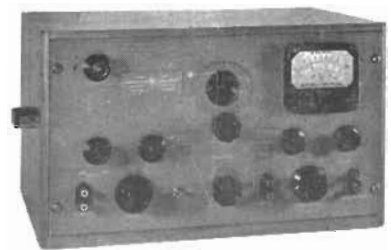

DISTORTION ANALYZER

This model 330B Distortion Analyzer is -hp-'s newest, finest distortion measuring instrument. It is capable of measuring distortion at any frequency between 20 cps and 20,000 cps. It will make noise measurements of voltages as small as 100 microvolts. A linear r-f detector makes it possible to measure these characteristics directly from a modulated r-f carrier. The high sensitivity, stable accuracy and compactness of the 330B make it extremely valuable for broadcast, laboratory and production measurements.

ADDITIONAL INSTRUMENTS ON REVERSE SIDE OF PAGE



LABORATORY INSTRUMENTS OF SPEED AND ACCURACY



FM MONITOR

-hp. Model 335B FM Monitor is a frequency monitor and modulation meter combined. It is F.C.C. approved, and is in wide use in FM stations. Special circuits in the Monitor permit fast, easy measurements of spurious am modulation as well as point-by-point measurements of percentage modulation. Other features include: provision for aural monitoring, remote metering, and 600-ohm audio output.



SECONDARY FREQUENCY STANDARDS

New *-hp.* Model 100D offers many advantages of a primary standard at much lower cost. Generates 100 kc, 10 kc, 1 kc, 100 cps, and 10 cps; stability 0.0001%. Sine or rectangular waves, 100 μ sec timing markers, built-in oscilloscope.

-hp. 100C offers sine waves only. Both have 5 v. output, accuracy .001%, self-contained power supply.

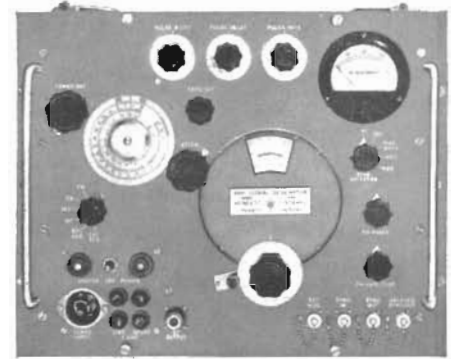

UHF SIGNAL GENERATOR

-hp. Model 616A UHF Signal Generator is the first instrument developed commercially which combines great operational speed, accuracy and ease of operation with a frequency range of 1800 mc to 4000 mc. R-f power is generated by a reflex klystron oscillator, and voltage adjustments during operation are eliminated by special *-hp.* automatic coupling device which causes oscillator repeller voltage to track frequency changes. The *-hp.* 616A features direct frequency and voltage control; c-w, f-m or pulsed output; plus wide variety of input and output delay and synchronization features.



MICROWAVE POWER METER

-hp. Model 430A Microwave Power Meter measures low-level microwave power from 0.1 milliwatt to 10 milliwatts full scale in 5 ranges. Power is read direct on large, 4" meter face. Instrument consists of a self-balancing bridge circuit using an external barretter as one arm. UHF power applied to the barretter indicated directly on meter. Instrument can be used at any microwave frequency for which external barretter and mount (not supplied) are available.



ELECTRONIC FREQUENCY METER

-hp. Model 500A Frequency Meter is designed to measure the frequency of an alternating voltage from 5 cps to 50 kc. It can be used to measure difference between two h-f signals. It is particularly suited to crystal grinding work where it can be used to measure the frequency deviation from the standard, quickly and accurately.



POWER SUPPLY UNIT

-hp. Model 710A Power Supply is an excellent source of d-c power for every laboratory and production department use. The power pack is designed for the utmost in flexibility, compactness, portability and economy. Output is continuously variable between 180 and 360 volts. The output voltage varies approximately 1 per cent with changes in load current up to 75 ma and with normal line variations. Noise and hum level is exceptionally low, and output unusually stable over a long period of time. Also contains auxiliary center-tapped 6.3 volt source providing 5 amperes of a-c.



SLOTTED LINE

-hp. Model 805A Slotted Line incorporates a radically new, different configuration known as the "parallel plane" design. It consists of two mechanically rigid planes, and a centerless ground silver-plated brass rod central conductor. The instrument is used to detect standing waves between 500 and 4,000 mc. It is designed for use with conventional 50 ohm systems. For use with 46.3 ohm, $\frac{7}{8}$ " coaxial systems, *-hp.* Model 805B is available.

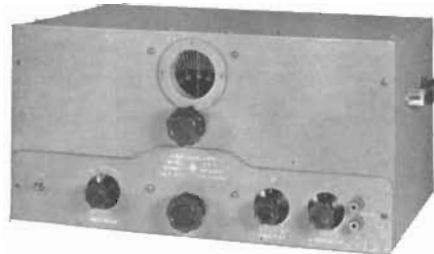

PRECISION OSCILLATORS

-hp. Model 201B and *-hp.* Model 2001 are precision measuring instruments of utmost accuracy and latest design. The 201B spans a range from 20 cps to 20 kc in three bands; the 2001, a spread-scale oscillator, covers frequencies from 6 to 6000 cps in six bands. Both include a 6" main frequency tuning dial calibrated over 300 degrees, controlled directly or by 6-1 micro-drive. Both meet all requirements for measurement speed, accuracy, and purity of wave form. And both instruments incorporate *-hp.* family characteristics of no zero set, constant output, and great stability.



UHF SIGNAL GENERATOR

-hp. Model 610B UHF Signal Generator is a precision instrument covering frequency range of 460 to 1,200 mc. Maximum output level is 0.1 volts into a 50-ohm impedance. Output frequency and power are selected on direct reading, direct control dials. Instrument contains an internal pulse generator permitting output rf pulse width to be varied from 2 to 50 microseconds, and pulse rate to be varied from 60 to 3,000 pps.

hp laboratory instruments

FOR SPEED AND ACCURACY

HEWLETT-PACKARD COMPANY
1320C PAGE MILL ROAD • PALO ALTO, CALIFORNIA